

– weishaupt –

# product

Information on oil, gas and dual fuel burners



WM 10 oil, gas and dual fuel version

Weishaupt monarch® WM10 burners • flexible application

# Advanced technology starts from tradition

## The new monarch<sup>®</sup> burner



*The Monarch<sup>®</sup> Trademark has represented performance and quality in burner industry for over 50 years*

For over five decades, Weishaupt monarch<sup>®</sup> series burners have been used on various heating and industrial process applications. Over this period of time, they have built an excellent reputation for Weishaupt.

With the new monarch<sup>®</sup> burner series this success story has been continued. The most modern technology, combined with a compact design allows this high performance burner to be universally utilized in various applications.

## Digital.

The digital combustion management system results in an economical and safe burner operation. The operation is simple.

## Compact.

The streamlined shape of the burner casing and the specially designed air ducting make it possible to achieve high capacity with compact size.

## Quiet.

Thanks to the newly designed blower unit, the new Monarch burners operate with lower sound levels.





# Digital

## Digital combustion management means optimum combustion values, always repeatable operating points and simple handling.

Weishaupt WM 10 series oil, gas and dual fuel burners are equipped with electronic fuel air ratio controller and digital combustion manager as standard. Modern heating applications require precise and always repeatable correct mixture of fuel and air. Only this way, optimum combustion values can be guaranteed for a long period of time.

### Simple operation

The programming of burner function is performed via the Display and Control unit. The unit is connected to the combustion manager via a BUS system.

## Flexible communication possibilities

The integrated interface makes it possible to receive and send all required information and control commands from and to the BMS system. If required, a modem can be installed so that remote monitoring and remote diagnostic function can be activated.

### BUS communication with remote control system or with BMS system

If data has to be exchanged between burners and other heating systems with PLC devices, the information can be accessible via either eBUS or MODBUS communication protocol. For control and management functions, Weishaupt offers ProGraf NT - a software product that provides real time solution to meet all requirements.

## Headstart with new technology

Digital combustion management makes burner operation simple and reliable. The most important benefits are:

- No additional burner controls are required since this function is already governed by the combustion manager. Fuses and eventually mains disconnect switch are the only additional items required.
- Less installation work means less errors: the burners are tested as a complete unit at the factory.
- Commissioning and service work take less time. The initial presetting of the burner is carried out at the factory. On site, only the site specific operating points have to be adjusted.

System overview	W-FM50	W-FM54	W-FM 100	W-FM 200
Digital Combustion Management				
Combustion manager for intermittent operation	●	●	●	●
Combustion manager for continuous operation			●	●
Flame sensor for intermittent operation	ION/QRA2/QRB	QRA2	ION/QRI/QRB	ION/QRI/QRB
Flame sensor for continuous operation	ION		ION/QRI	ION/QRI
Number of actuator (max.)	2 pcs	3 pcs	4 pcs	6 pcs
Actuator with stepping motor	●	●	●	●
Compatible with Variable Speed Drive operation	●	●		●
O <sub>2</sub> -Trim (optional)			●	
Single fuel operation	●		●	●
Dual fuel operation		●	●	●
Valve proving system for gas valves	●	●	●	●
Integrated self tuning PID-Modulating controller for Temperature or Pressure			●	●
Removable ABE control unit (max. distance)	65 ft (20 m)	65 ft (20 m)	325 ft (100 m)	325 ft (100 m)
Fuel meter interface	● <sup>1)</sup>	● <sup>1)</sup>		●
Combustion efficiency display (w/ optional sensor)				●
eBUS / MOD BUS interface	●	●	●	●
PC interface	●	●	●	●

<sup>1)</sup> Not in conjunction with VFD operation

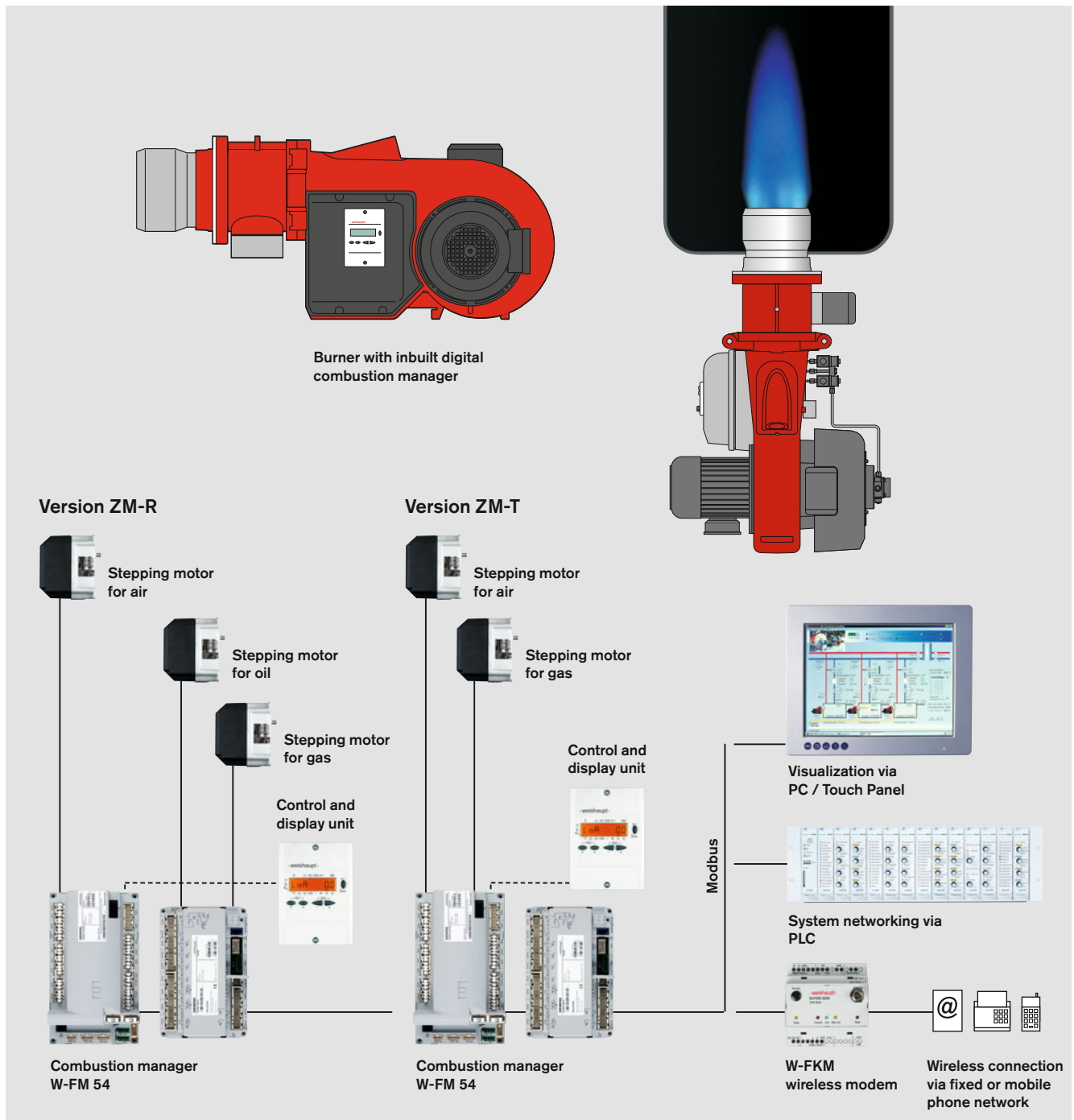

Connection schematic with W-FM 54

# Compact and Quiet

**The newly developed Weishaupt monarch® burner WM 10 is compact, efficient and quiet. It is the continuation of the 50 years success history of the legendary monarch® series.**

## **Advanced blower fan technology**

Even during the development phase of this new burner generation, future oriented blower fan technology has been utilized to achieve a compact, streamlined design and low operating noise.

To achieve the goal, not only the air guide but also the air damper control has been completely redesigned. The specially designed burner casing in conjunction with the new air guide and air damper technology result in a positive fan pressure and therefore more power from a compact design.

The air damper control is responsible for a linear characteristic even in the low firing rate and in conjunction with the standard air inlet sound absorber a quiet burner operation is made possible.

## **Quick commissioning, easy maintenance**

All WM 10 burners are shipped out with an adjustable mixing head. Individual adjustment is to be performed via commissioning program in the combustion manager.

Despite its compact design all components such as mixing head, air damper and combustion manager are easily accessible. Therefore maintenance and service work can be performed easily and quickly. The standard hinged flange allows an ideal service position for the burner.

Matching to various combustion chamber geometries can be performed directly on the burner. The flame and the ignition process can be observed via the integrated viewing port.

## **Flexible control capability**

WM 10 burners are available with the following control options:

Oil: 3-stage (T)  
modulating (R)  
Gas: Sliding two stage or  
modulating (ZM)

This allows flexible control possibilities, which make the burner universally adaptable to various applications. Both versions result in a smooth, trouble free start and reliable operation.

## **Various versions are available to meet different emission and operation requirements:**

### **ZM version**

Standard version for gas and dual fuel burners.

### **LN (LowNOx) version**

Low NOx version of WM gas burners. The low NOx emission is achieved by increased recirculation of combustion gases.

Compliance to certain emission requirement is also dependant on combustion chamber geometry, volume loading and design of the combustion system.

### **ZMI version**

Gas burner with higher turn down ratio for special industrial applications.

### **3LN multiflam® version**

Patented multiflam technology for oil, gas and dual fuel burners. Low NOx emission is achieved by special fuel distribution.

### **Suitable fuel**

Natural Gas  
Propane  
Light Oil #2 according to ASTM D396

Different type of fuel requires written confirmation from Weishaupt.

## **Applications**

Weishaupt WM 10 oil, gas and dual fuel burners are suitable to be used for the following:

- Installation on heat exchanger
- Warm water boiler
- Steam boiler and hot water boiler
- Intermittent and continuous operation
- Hot air generator

The combustion air must be free from any aggressive substances (Halogen, Chloride, Fluoride, etc) and contamination (dust, building materials, vapours, etc). For many cases an external air ducting to the burner is recommended as an option.

## **Permissible environmental conditions:**

- Operation temperature  
14 to 104F (-10 to +40 °C) dual fuel  
5 to 104F (-15 to +40 °C) gas
- Air humidity: max. 80 % relative humidity, no condensation
- For indoor operation only
- For installation in unheated rooms under some circumstances special solutions are required (contact Weishaupt)

Any discrepancy from the above described applications requires written confirmation from Weishaupt Corporation. The maintenance interval could be shortened according to conditions where the burners are installed.

## **Approvals**

WM 10 series burners are in compliance with most European and North American applicable standards.

## **The most important advantages at a glance:**

- Digital combustion manager for all firing rates
- Easy switching between gas and oil operation
- More compact design in comparison with burners in the same rating class

- Quiet operation due to air inlet equipped with sound absorbing material
- High performance blower due to specially designed blower geometry and air damper control system
- All WM 10 burners are equipped with adjustable flame tube
- Protection class IP 54 as standard
- Easy access to all components, such as: mixing head, air damper and combustion manager
- Computer aided function test of each individual burner in the factory
- Excellent price to performance ratio
- Worldwide service network

### Excellent Design

To make quality visible has been our basic value since the company was established by Max Weishaupt

This value is translated in all aspects of the company: in its architecture, its product design and its end product.

Numerous design prizes confirm the success. The monarch® WM 10 burner for example has been awarded for its excellent product design with red dot award.



reddot award  
product design

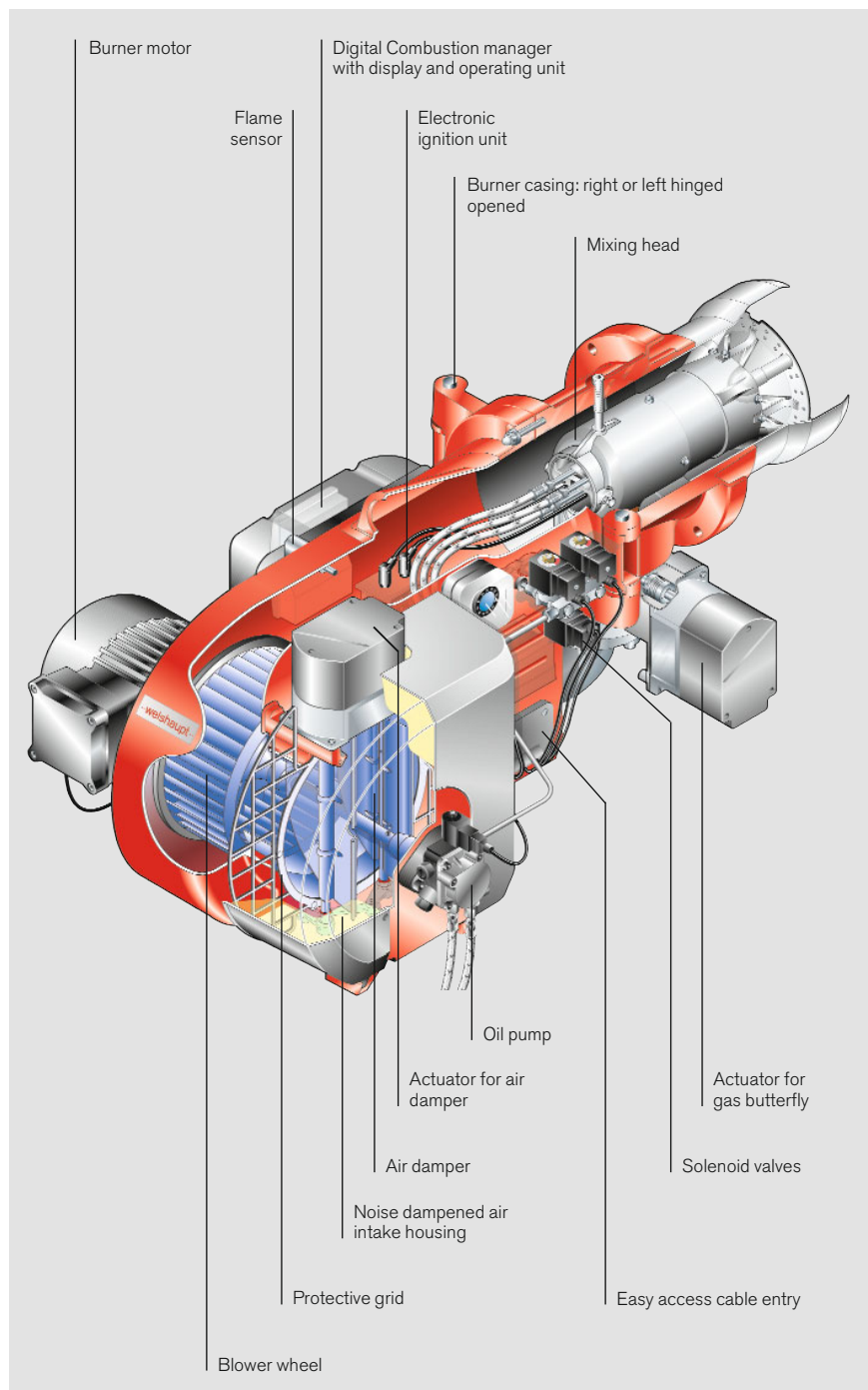

WM-GL10 Version ZM-T

# Overview of operating modes

## Burner's nomenclature

### Operating modes with oil

#### Capacity regulation ZM-T

- Oil release during start by opening the solenoid valve 1 and safety solenoid valve
- Highfire is achieved by opening solenoid valves 2 and 3
- Firing rate is controlled by opening and closing solenoid valves 2 and 3

#### Capacity regulation ZM-R

- By opening the solenoid valve, oil amount required for ignition is released
- A digital stepping motor regulates the oil regulator up to full capacity
- Burner firing rate between low and highfire is controlled by opening and closing oil regulator
- Integrated or external modulating controller can be used as firing rate controller.

#### 3-stage

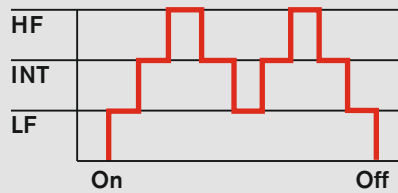

#### sliding stage

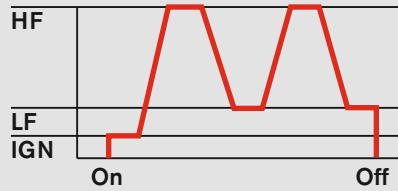

#### modulating

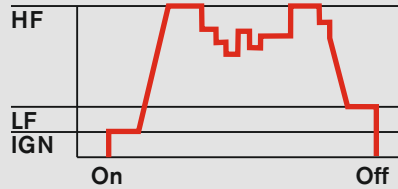

### Operating modes with gas

#### Capacity regulation ZM (sliding-stage or modulating)

- Burner capacity between low and highfire depending on heat requirement is controlled by stepping motor
- Anywhere between both operating points the burner can be operated. There are no sudden changes of fuel flow
- Option for combustion manager:
  - W-FM 50 (single fuel application) with additional modulating controller
  - W-FM 54 (dual fuel application) with additional modulating controller
  - W-FM 100 (single/ dual fuel) with integrated modulating controller
  - W-FM 200 (single/ dual fuel)
- Alternatively an external modulating controller can also be used for that purpose.

HF = Highfire  
 INT = Intermediary fire  
 LF = Lowfire  
 IGN = Ignition

Fuel Version	Oil			Gas	
	3-stage	sliding-stage	modulating	sliding-stage	modulating
ZM				●	●
ZM-T	●			●	●
ZM-R		●	●	●	●

### Nomenclature

WM - GL 10 / 3 -A / ZM - T  
 ZM - R

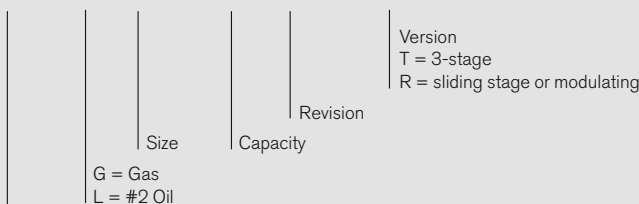



# Burner selection WM-L10 Oil burners version T and R

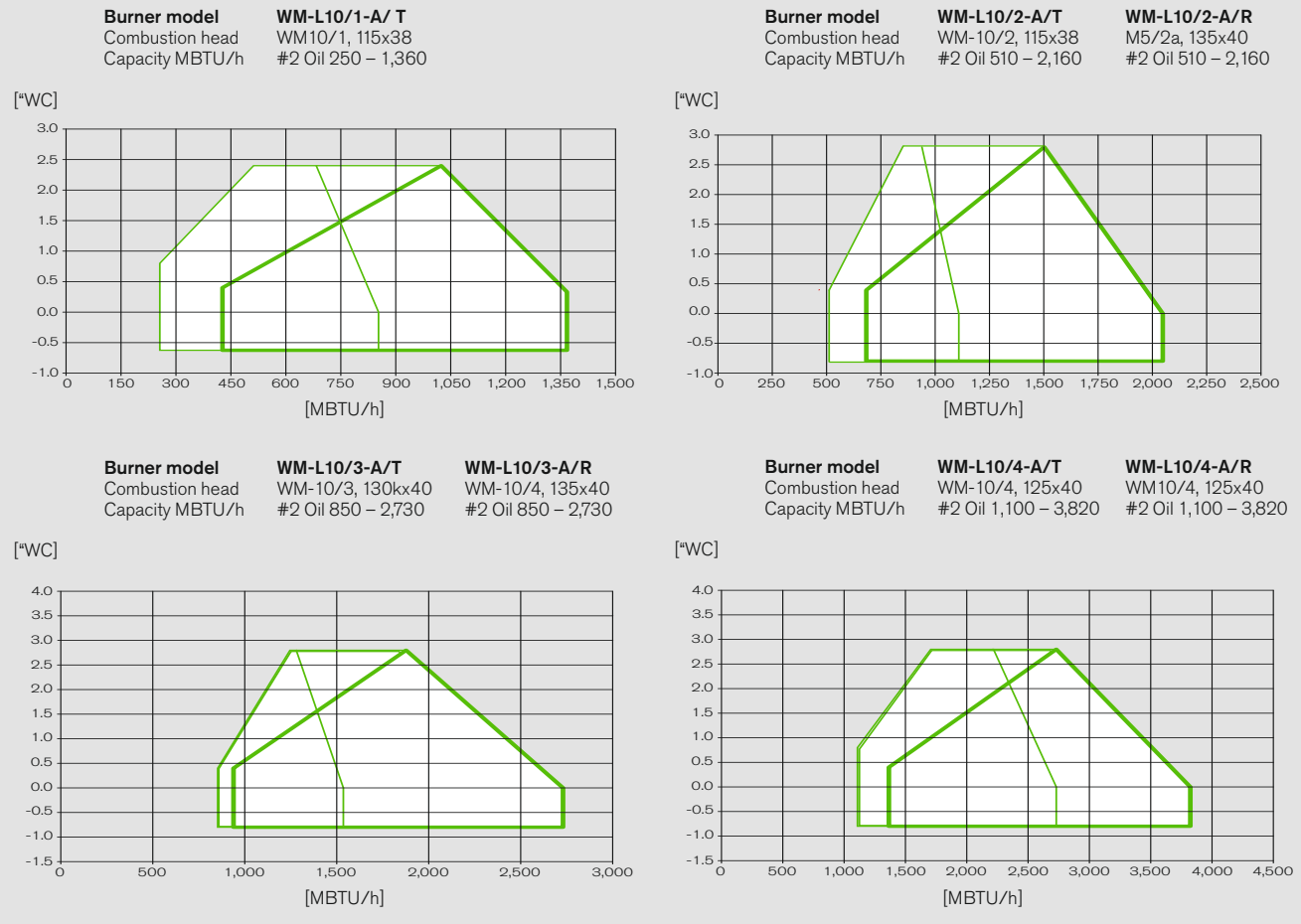

#2 Oil with flame tube  
close   
open

The capacity graphs are based on an installation altitude of 1,640 ft (500 m).  
Burner capacities are based on #2 oil with calorific value of 140,000 BTU/Gallon

# Burner selection WM-G10

## Gas burners version ZM

**Burner model** WM-G10/1-A ZM  
 Combustion head WM10/2-1a, 135 K x 40  
 Capacity MBTU/h Natural gas 190 – 1,360  
 Propane 220 – 1,360

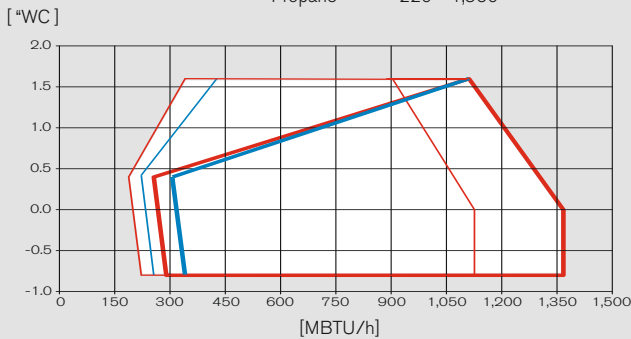

**Burner model** WM-G10/2-A ZM  
 Combustion head WMGL10-2/1a, 129 K x 40  
 Capacity MBTU/h Natural gas 220 – 2,150  
 Propane 340 – 2,150

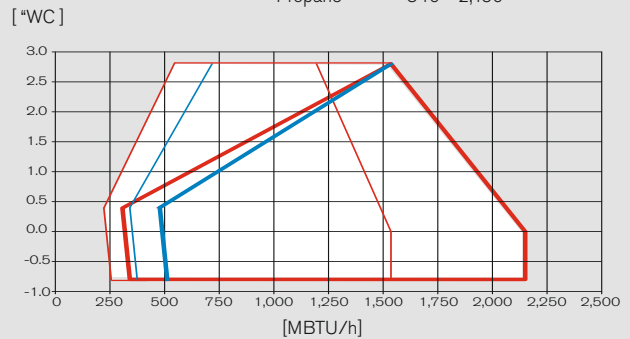

**Burner model** WM-G10/3-A ZM  
 Combustion head WMGL10-3/1a, 170 K x 50  
 Capacity MBTU/h Natural gas 340 – 3,400  
 Propane 410 – 3,400

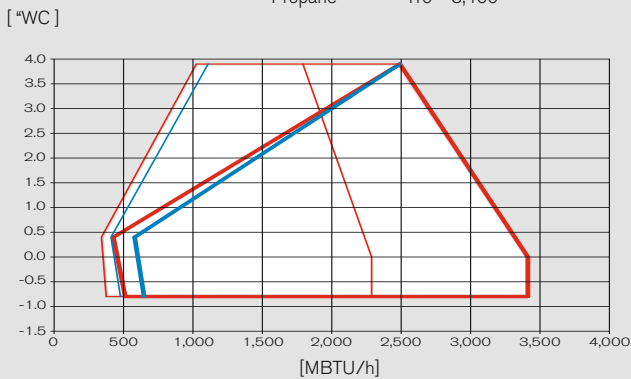

**Burner model** WM-G10/4-A ZM  
 Combustion head WMGL10-3/1a, 170 K x 50  
 Capacity MBTU/h Natural gas 375 – 4,265  
 Propane 850 – 4,265

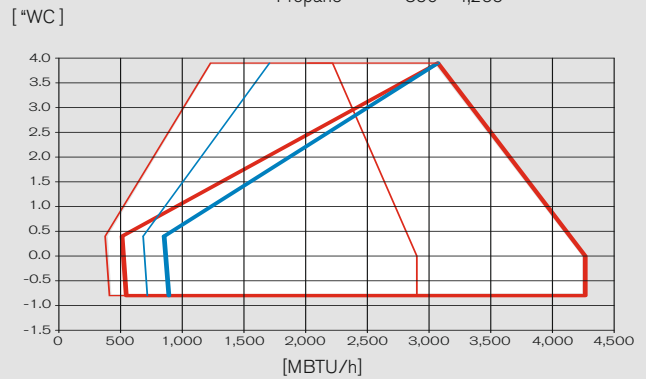

**Natural gas with flame tube**      **Propane with flame tube**  
 close ——— (red line)                      close ——— (blue line)  
 open ——— (red line)                        open ——— (blue line)

The capacity graphs are based on sea level (0 ft/ m altitude). Capacity reduction may apply depending on the altitude of the installation. Approximately 1 % capacity reduction per 328ft (100 m) above sea level should be considered.

# Burner selection WM-G10 Gas burners version ZM-LN

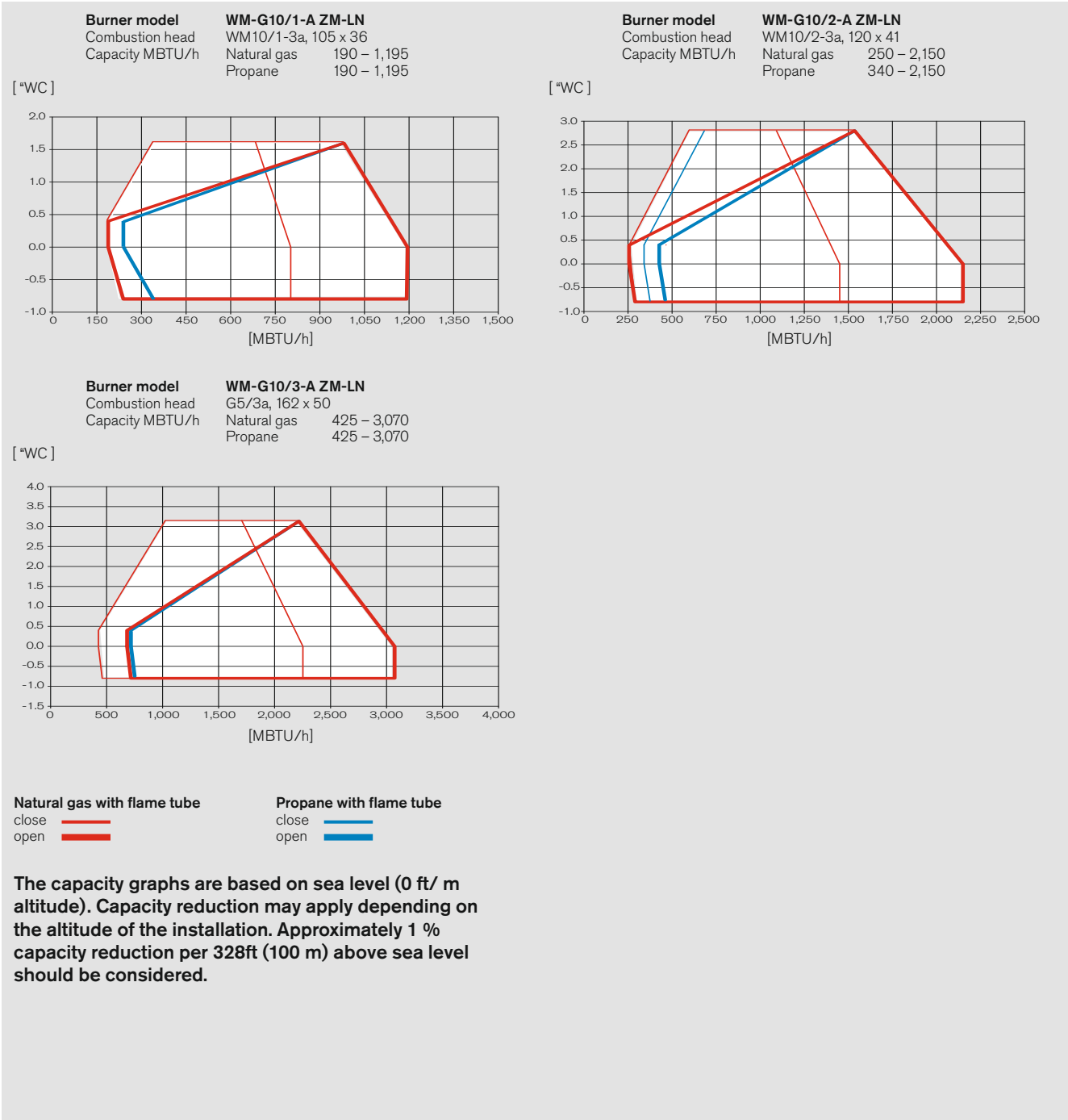

# Burner selection WM-GL10

## Dual fuel burners version ZM-T and ZM-R

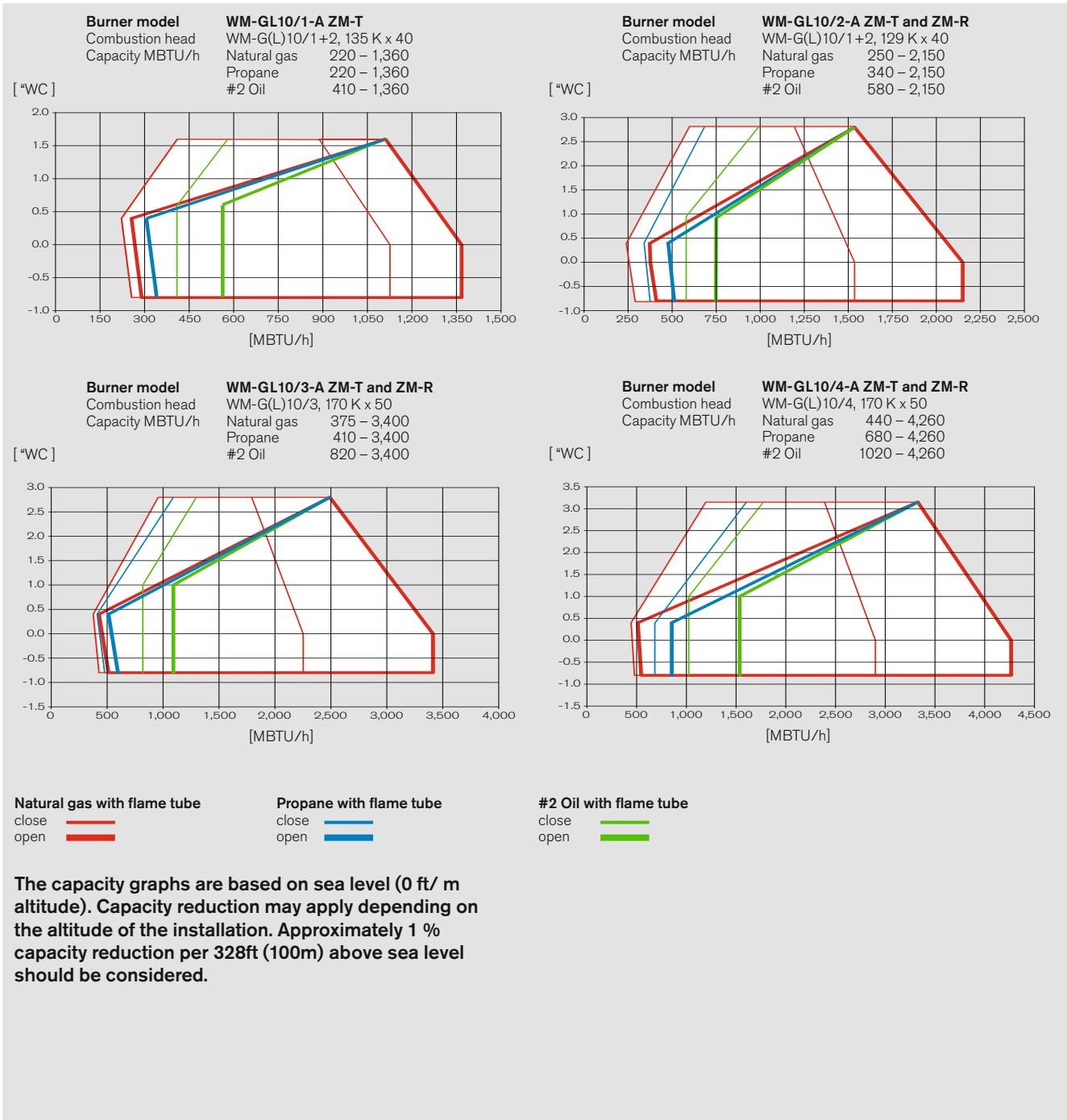

## Standard scope of supply

Description	WM-L10-T	WM-L10-R	WM-G10 ZM/LN	WM-GL10 ZM-T	WM-GL10 ZM-R
Burner housing, hinge flange, housing cover, Weishaupt burner motor, air intake housing, fan wheel, combustion head, ignition unit, ignition cable, ignition electrode, combustion manager with operating unit, flame sensor, stepping motors, flange gasket, limit switch on hinge flange, fixing screws	●	●	●	●	●
Digital combustion manager W-FM 50	●	●	●	-	-
W-FM 54	-	-	-	●	●
W-FM 100	○	○	○ [● ZMI]	○	○
Two gas safety shut off valves	-	-	●	●	●
Gas butterfly valve	-	-	●	●	●
Air pressure switch	-	-	●	●	●
Adjustable flame tube	●	●	●	●	●
Stepping motor for electronic fuel-air ratio controller					
Stepping motor for air damper	●	●	●	●	●
Stepping motor for gas butterfly valve	-	-	●	●	●
Stepping motor for oil regulator	-	●	-	-	●
Oil pressure switch in return line	-	●	-	-	●
Burner mounted oil pump	●	●	-	●	●
Oil hoses	●	●	-	●	●
4 oil solenoid valves, oil regulator, nozzle head with premounted spill type nozzle	-	●	-	-	●
3 oil solenoid valve, three stage nozzle head with premounted oil nozzle	●	-	-	●	-
1 additional oil safety solenoid valve	○			●	
Magnetic clutch	○	○	-	○	● <sup>1)</sup>
IP 54 protection	●	●	●	●	●

- Standard
- Optional

<sup>1)</sup> starting from second quarter of 2011



# Order numbers

## Oil burners version T

Burner model three stage	Order No.
WM-L10/1-A/ T	211 110 10
WM-L10/2-A/ T	211 110 20
WM-L10/3-A/ T	211 110 30
WM-L10/4-A/ T	211 110 40

## Gas burners version ZM

Burner model	Version	Order No.
WM-G10/1	ZM	217 111 10
WM-G10/2	ZM	217 114 10
WM-G10/3	ZM	217 117 10
WM-G10/4	ZM	217 120 11

## Version ZM-T

Burner model	Version	Order No.
WM-GL10/1	ZM-T	218 111 10
WM-GL10/2	ZM-T	218 112 10
WM-GL10/3	ZM-T	218 113 10
WM-GL10/4	ZM-T	218 114 11

## Oil burners version R

Burner model modulating	Order No.
–	–
WM-L10/2-A/ R	215 110 20
WM-L10/3-A/ R	215 110 30
WM-L10/4-A/ R	215 110 40

## Gas burners version ZM-LN

Burner model	Version	Order No.
WM-G10/1	ZM-LN	217 112 10
WM-G10/2	ZM-LN	217 115 10
WM-G10/3	ZM-LN	217 118 10

## Version ZM-R

Burner model	Version	Order No.
WM-GL10/2	ZM-R	218 115 10
WM-GL10/3	ZM-R	218 116 10
WM-GL10/4	ZM-R	218 117 11

# Accessories

## Oil burners

<b>Version T (3 stage)</b>		<b>WM-L 10/1-A/T</b>	<b>WM-L 10/2-A/T</b>	<b>WM-L 10/3-A/T</b>	<b>WM-L 10/4-A/T</b>
Combustion head extension	by 4" (100 mm)	210 030 16	210 030 00	210 030 02	210 030 04
	by 8" (200 mm)	210 030 17	210 030 01	210 030 03	210 030 05
Oil hose 50" (1300 mm) in lieu of 39" ( 1000 mm)		210 003 00	210 003 00	210 003 00	210 003 00
Connection for air inlet ducting		210 030 20	210 030 20	210 030 20	210 030 20
Oil meter VZ08 without pulse output, incl. safety isolation valve		210 030 07	210 030 07	210 030 07	210 030 07
Oil meter VZ08 with pulse output NF, incl. safety isolation valve		210 030 09	210 030 09	210 030 09	210 030 09
W-FM 100 (suitable for cont. operation) instead of W-FM 50 with built in modulating controller	fitted	210 030 32	210 030 32	210 030 32	210 030 32
	loose	on request	on request	on request	on request
W-FM 200 instead of W-FM 50 with built in modulating controller and VFD control with optional fuel metering	fitted	210 030 10	210 030 10	210 030 10	210 030 10
	loose	on request	on request	on request	on request
QRI flame sensor in lieu of QRB		210 030 24	210 030 24	210 030 24	210 030 24
Oil meter VZ08		250 030 46	250 030 46	250 030 46	250 030 46
Oil meter VZ08 with remote transmitter LF		250 030 47	250 030 47	250 030 47	250 030 47
Special voltage (on request only)		on request	on request	on request	on request

<b>Version R (sliding two stage or modulating)</b>		<b>WM-L 10/2-A/R</b>	<b>WM-L 10/3-A/R</b>	<b>WM-L 10/4-A/R</b>
Combustion head extension	by 4" (100 mm)	250 030 25	250 030 27	250 030 29
	by 8" (200 mm)	250 030 26	250 030 28	250 030 30
Oil hose 50" (1300 mm) in lieu of 39" ( 1000 mm)		210 003 00	210 003 00	210 003 00
Connection for air inlet ducting		210 030 20	210 030 20	210 030 20
W-FM 100 (suitable for cont. operation) inst. W-FM 50 with built in modulating controller	fitted	210 030 38	210 030 38	210 030 38
	loose	on request	on request	on request
W-FM 200 instead of W-FM 50 with built in modulating controller and VFD control with optional fuel metering	fitted	210 030 39	210 030 39	210 030 39
	loose	on request	on request	on request
QRI flame sensor in lieu of QRB		210 030 24	210 030 24	210 030 24
Speed control with burner motor mounted VFD (W-FM 50/200 required)		on request	on request	on request
Speed control with separate VFD (W-FM 50/200 required)		on request	on request	on request
Special voltages (on request only)		on request	on request	on request

# Accessories

## Gas burners

Accessories for version ZM		WM-G 10/1-A / ZM	WM-G 10/2-A / ZM	WM-G 10/3-A / ZM	WM-G 10/4-A / ZM
Combustion head extension	by 4" (100 mm)	250 030 00	250 030 03	250 030 06	250 030 09
	by 8" (200 mm)	250 030 01	250 030 04	250 030 07	250 030 10
	by 12" (300 mm)	250 030 02	250 030 05	250 030 08	250 030 11
Solenoid valve for air pressure switch test for continuous run fan or post purge		250 030 21	250 030 21	250 030 21	250 030 21
W-FM 100 (suitable for cont. operation) instead of W-FM 50	fitted	250 030 74	250 030 74	250 030 74	250 030 74
	loose	250 030 45	250 030 45	250 030 45	250 030 45
W-FM 200 instead of W-FM 50 with built in modulating controller and VFD control optional fuel metering	fitted	250 030 75	250 030 75	250 030 75	250 030 75
	loose	250 030 48	250 030 48	250 030 48	250 030 48
Speed control with burner motor mounted VFD (W-FM 50/200 required)		on request	on request	on request	on request
Speed control with separate VFD (W-FM 50/200 required)		on request	on request	on request	on request
Special voltages (on request only)		on request	on request	on request	on request

Accessories for version ZM-LN		WM-G 10/1-A / ZM-LN	WM-G 10/2-A / ZM-LN	WM-G 10/3-A / ZM-LN
Combustion head extension	by 4" (100 mm)	250 030 12	250 030 15	250 030 18
	by 8" (200 mm)	250 030 13	250 030 16	250 030 19
	by 12" (300 mm)	250 030 14	250 030 17	250 030 20
Solenoid valve for air pressure switch test for continuous run fan or post purge		250 030 21	250 030 21	250 030 21
W-FM 100 (suitable for cont. operation) instead of W-FM 50	fitted	250 030 74	250 030 74	250 030 74
	loose	250 030 45	250 030 45	250 030 45
W-FM 200 instead of W-FM 50 with built in modulating controller and VFD control with optional fuel metering	fitted	250 030 75	250 030 75	250 030 75
	loose	250 030 48	250 030 48	250 030 48
Speed control with burner motor mounted VFD (W-FM 50/200 required)		on request	on request	on request
Speed control with separate VFD (W-FM 50/200 required)		on request	on request	on request
Special voltages (on request only)		on request	on request	on request

# Accessories

## Dual fuel burners

Accessories for version ZM-T		WM-GL 10/1-A	WM-GL 10/2-A	WM-GL 10/3-A	WM-GL 10/4-A
Combustion head extension	by 4" (100 mm)	250 030 50	250 030 53	250 030 56	250 030 59
	by 8" (200 mm)	250 030 51	250 030 54	250 030 57	250 030 60
	by 12" (300 mm)	250 030 52	250 030 55	250 030 58	250 030 61
Solenoid valve for air press. switch test - cont. run fan or post purge		250 030 21	250 030 21	250 030 21	250 030 21
2 stage instead of 3 stage (low impact star)		210 030 31	210 030 31	210 030 31	210 030 31
Electromagnetic clutch for oil pump		250 030 44	250 030 44	250 030 44	250 030 44
W-FM 100 (suitable for cont. operation) inst. W-FM 54 with built in modulating controller	fitted	250 031 78	250 031 78	250 031 78	250 031 78
	loose	on request	on request	on request	on request
W-FM 200 instead of W-FM 54 with built in modulating controller and VFD control with optional fuel metering	fitted	250 031 77	250 031 77	250 031 77	250 031 77
	loose	on request	on request	on request	on request
Speed control with burner motor mounted VFD (W-FM 54/200 required)		on request	on request	on request	on request
Speed control with separate VFD (W-FM 54/200 required)		on request	on request	on request	on request
Oil hoses 50" (1300) mm instead of 40" (1000 mm)		210 003 00	210 003 00	210 003 00	210 003 00
Oil meter VZ08		250 030 46	250 030 46	250 030 46	250 030 46
Oil meter VZ08 with remote transmitter LF		250 030 47	250 030 47	250 030 47	250 030 47
Special voltage (on request only)		on request	on request	on request	on request

Accessories for version ZM-R		WM-GL 10/2-A	WM-GL 10/3-A	WM-GL 10/4-A
Combustion head extension	by 4" (100 mm)	250 030 62	250 030 65	250 030 68
	by 8" (200 mm)	250 030 63	250 030 66	250 030 69
	by 12" (300 mm)	250 030 64	250 030 67	250 030 70
Solenoid valve for air press. switch test - cont. run fan or post purge		250 030 21	250 030 21	250 030 21
Electromagnetic clutch for oil pump		250 030 44	250 030 44	250 030 44
W-FM 100 (suitable for cont. operation) inst. W-FM 54 with built in modulating controller	fitted	250 031 78	250 031 78	250 031 78
	loose	on request	on request	on request
W-FM 200 instead of W-FM 54 with built in modulating controller and VFD control with optional fuel metering	fitted	250 031 77	250 031 77	250 031 77
	loose	on request	on request	on request
Speed control with burner motor mounted VFD (W-FM 54/200 required)		on request	on request	on request
Speed control with separate VFD (W-FM 54/200 required)		on request	on request	on request
Special voltages (on request only)		on request	on request	on request

# Technical Data

## Technical data

Oil burners version T / R		WM-L10/1-A / T	WM-L 10/2-A / T WM-L 10/2-A / R	WM-L 10/3-A / T WM-L 10/3-A / R	WM-L 10/4-A / T WM-L 10/4-A / R
Burner motor	Weishaupt model	WM-D90/90-2/1K0	WM-D90/90-2/1K0	WM-D90/90-2/1K5	WM-D90/90-2/1K5
Rated power	HP (kW)	1.34 (1.0)	1.34 (1.0)	2.14 (1.6)	2.14 (1.6)
Current	A	2.0 (@ 460 V)	2.0 (@ 460 V)	3.1 (@ 460 V)	3.1 (@ 460 V)
Motor fusing (direct online)	A minimal	16 A slow (external)	16 A slow (external)	16 A slow (external)	16 A slow (external)
Speed (60 Hz)	rpm	3,500	3,500	3,480	3,480
Combustion manager	Model	W-FM 50	W-FM 50	W-FM 50	W-FM 50
Flame monitoring	Model	ORB	ORB	ORB	ORB
Stepping motor air/gas	Model	SQM 33	SQM 33	SQM 33	SQM 33
Burner mounted oil pump	Model	AL 75C	AL 75C	AL 95C	AL 95C
	GPH (l/h)	34 (130)	34 (130)	39 (150)	39 (150)
Oil hoses	Model	–	AJ6	AJ6	AJ6
	GPH (l/h)	–	90 (350)	90 (350)	90 (350)
Oil hoses	DN/length	5/16" / 40" (8/1000)	5/16" / 40" (8/1000)	5/16" / 40" (8/1000)	5/16" / 40" (8/1000)
Weight	lbs (kg)	approx. 110 (50)	approx. 110 (50)	approx. 110 (50)	approx. 110 (50)

### Voltages and frequencies:

As standard, the burners are suitable for three phase alternating current with voltages available between 208 - 600V, 60Hz. Different voltages and frequency available on request.

### Standard burner motor:

Isolation class F, IP 54 protection



## Technical Data

### Technical data

Gas burners version ZM / ZM-LN		WM-G10/1-A / ZM WM-G10/1-A / ZM-LN	WM-G 10/2-A / ZM WM-G 10/2-A / ZM-LN	WM-G 10/3-A / ZM WM-G 10/3-A / ZM-LN	WM-G 10/4-A / ZM
Burner motor	Weishaupt model	WM-D90/90-2/1K0	WM-D90/90-2/1K0	WM-D90/90-2/1K5	WM-D90/90-2/1K5
Rated power	HP (kW)	1.34 (1.0)	1.34 (1.0)	2.14 (1.6)	2.14 (1.6)
Current	A	2.0 (@ 460 V)	2.0 (@ 460 V)	3.1 (@ 460 V)	3.1 (@ 460 V)
Motor fusing (direct online)	A minimal	16 A slow (external)	16 A slow (external)	16 A slow (external)	16 A slow (external)
Speed (60 Hz)	rpm	3,500	3,500	3,480	3,480
Combustion manager	Model	W-FM 50	W-FM 50	W-FM 50	W-FM 50
Flame monitoring	Model	ION	ION	ION	ION
Stepping motor air/gas	Model	SQM 33	SQM 33	SQM 33	SQM 33
Weight	lbs (kg)	approx. 120 (54)	approx. 120 (54)	approx. 125 (56)	approx. 125 (56)

Dual fuel burners version ZM-T		WM-GL 10/1-A	WM-GL 10/2-A	WM-GL 10/3-A	WM-GL 10/4-A
Burner motor	Weishaupt model	WM-D90/90-2/1K0	WM-D90/90-2/1K0	WM-D90/90-2/1K5	WM-D90/90-2/1K5
Rated power	HP (kW)	1.34 (1.0)	1.34 (1.0)	2.14 (1.6)	2.14 (1.6)
Current	A	2.0 (@ 460 V)	2.0 (@ 460 V)	3.1 (@ 460 V)	3.1 (@ 460 V)
Motor fusing (direct online)	A minimal	16 A slow (external)	16 A slow (external)	16 A slow (external)	16 A slow (external)
Speed (60 Hz)	rpm	3,500	3,500	3,480	3,480
Combustion manager	Model	W-FM 54	W-FM 54	W-FM 54	W-FM 54
Flame monitoring	Model	QRA2	QRA2	QRA2	QRA2
Stepping motor air/gas	Model	SQM 33	SQM 33	SQM 33	SQM 33
Burner mounted oil pump	Model GPH (l/h)	AL 75C 34 (130)	AL 75C 34 (130)	AL 95C 39 (150)	AJ6 90 (350)
Oil hoses	DN/length	5/16" / 40" (8/1000)	5/16" / 40" (8/1000)	5/16" / 40" (8/1000)	5/16" / 40" (8/1000)
Weight	lbs (kg)	approx. 128 (58)	approx. 128 (58)	approx. 128 (58)	approx. 128 (58)

Dual fuel burners version ZM-R		WM-GL 10/2-A	WM-GL 10/3-A	WM-GL 10/4-A
Burner motor	Weishaupt model	WM-D90/90-2/1K0	WM-D90/90-2/1K5	WM-D90/90-2/1K5
Rated power	HP (kW)	1.34 (1.0)	2.14 (1.6)	2.14 (1.6)
Current	A	2.0 (@ 460 V)	3.1 (@ 460 V)	3.1 (@ 460 V)
Motor fusing (direct online)	A minimal	16 A slow (external)	16 A slow (external)	16 A slow (external)
Speed (60 Hz)	rpm	3,500	3,480	3,480
Combustion manager	Model	W-FM 54	W-FM 54	W-FM 54
Flame monitoring	Model	QRA2	QRA2	QRA2
Stepping motor air/gas/ oil	Model	STE 50	STE 50	STE 50
Burner mounted oil pump	Model GPH (l/h)	AJ6 90 (350)	AJ6 90 (350)	AJ6 90 (350)
Oil hoses	DN/length	5/16" / 40" (8/1000)	5/16" / 40" (8/1000)	5/16" / 40" (8/1000)
Weight	lbs (kg)	approx. 128 (58)	approx. 128 (58)	approx. 128 (58)

# Dimensions

## Oil burners

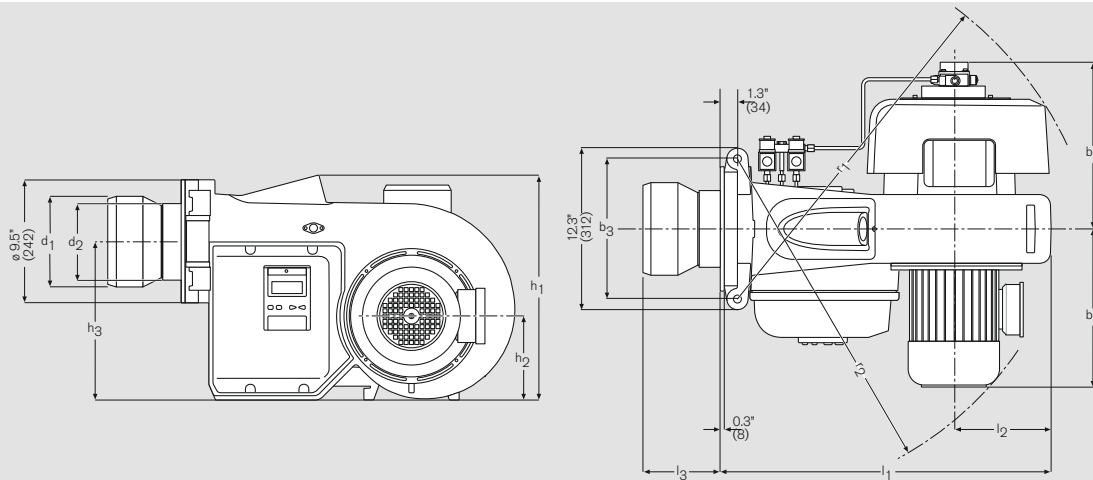

Burner model	Dimensions in inches and (mm)															
	$l_1$	$l_2$	$l_3$	$b_1$	$b_2$	$b_3$	$h_1$	$h_2$	$h_3$	$r_1$	$r_2$	$d_1$	$d_2$	$d_3$	$d_4$	$d_5$
WM-L10/1-A/T	25.9 (659)	8.1 (205)	4.6 - 5.4 (118 - 138)	12.7 (323)	12.1 (307)	10.6 (270)	17.5 (445)	6.6 (167)	12.3 (313)	28.3 (718)	26.9 (682)	5.5 (140)	6.1 (155)	M10	6.5 (165)	7.3 (186)
WM-L10/2-A/T	25.9 (659)	8.1 (205)	5.0 - 5.8 (127 - 147)	12.7 (323)	12.1 (307)	10.6 (270)	17.5 (445)	6.6 (167)	12.3 (313)	28.3 (718)	26.9 (682)	5.5 (140)	6.1 (155)	M10	6.5 (165)	7.3 (186)
WM-L10/3-A/T	25.9 (659)	8.1 (205)	5.8 - 6.6 (147 - 167)	12.7 (323)	12.1 (307)	10.6 (270)	17.5 (445)	6.6 (167)	12.3 (313)	28.3 (718)	26.9 (682)	6.3 (160)	6.1 (155)	M10	7.3 (185)	8.3 (210)
WM-L10/4-A/T	25.9 (659)	8.1 (205)	5.8 - 6.6 (148 - 168)	12.7 (323)	12.1 (307)	10.6 (270)	17.5 (445)	6.6 (167)	12.3 (313)	28.3 (718)	26.9 (682)	7.1 (180)	6.1 (155)	M10	7.3 (185)	8.3 (210)
WM-L10/2-A/R	25.9 (659)	8.1 (205)	5.2 - 5.7 (131 - 146)	13.8 (352)	12.1 (307)	10.6 (270)	17.5 (445)	6.6 (167)	12.3 (313)	28.3 (718)	26.9 (682)	5.5 (140)	6.1 (155)	M10	6.5 (165)	7.3 (186)
WM-L10/3-A/R	25.9 (659)	8.1 (205)	6.1 - 6.7 (156 - 171)	13.8 (352)	12.1 (307)	10.6 (270)	17.5 (445)	6.6 (167)	12.3 (313)	28.3 (718)	26.9 (682)	6.3 (160)	6.1 (155)	M10	7.3 (185)	8.3 (210)
WM-L10/4-A/R	25.9 (659)	8.1 (205)	5.9 - 6.5 (151 - 166)	13.8 (352)	12.1 (307)	10.6 (270)	17.5 (445)	6.6 (167)	12.3 (313)	28.3 (718)	26.9 (682)	7.1 (180)	6.1 (155)	M10	7.3 (185)	8.3 (210)

Dimensions given are approximate values. We reserve the right to make changes in line with future developments.

### Boiler plate mounting dimensions

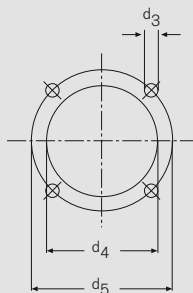

# Dimensions Gas burners

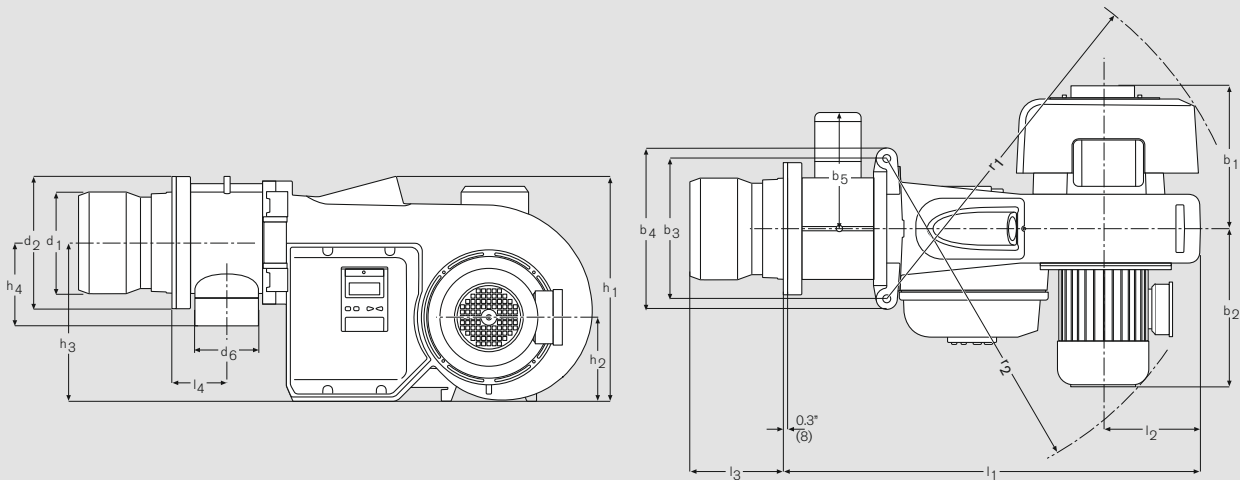

Burner Model	Dimensions in inches and (mm)															
	l <sub>1</sub>	l <sub>2</sub>	l <sub>3</sub>	l <sub>4</sub>	b <sub>1</sub>	b <sub>2</sub>	b <sub>3</sub>	b <sub>4</sub>	b <sub>5</sub>	h <sub>1</sub>	h <sub>2</sub>	h <sub>3</sub>	h <sub>4</sub>	r <sub>1</sub>	r <sub>2</sub>	
<b>WM-G10/1 ZM</b>	32.0 (813)	8.1 (205)	6.7 – 7.0 (171 – 178)	3.9 (98)	11.0 (279)	12.1 (307)	10.6 (270)	12.3 (312)	9.1 (232)	175 (445)	6.6 (167)	12.3 (313)	5.5 (140)	28.3 (718)	26.9 (682)	
<b>WM-G10/2 ZM</b>	32.0 (813)	8.1 (205)	6.2 – 7.0 (158 – 178)	3.9 (98)	11.0 (279)	12.1 (307)	10.6 (270)	12.3 (312)	9.1 (232)	175 (445)	6.6 (167)	12.3 (313)	5.5 (140)	28.3 (718)	26.9 (682)	
<b>WM-G10/3 ZM</b>	32.8 (833)	8.1 (205)	7.8 – 8.8 (199 – 224)	4.3 (108)	11.0 (279)	12.1 (307)	10.6 (270)	12.3 (312)	9.1 (240)	175 (445)	6.6 (167)	12.3 (313)	6.4 (162)	28.3 (718)	26.9 (682)	
<b>WM-G10/4 ZM</b>	32.8 (833)	8.1 (205)	7.8 – 8.8 (199 – 224)	4.3 (108)	11.0 (279)	12.1 (307)	10.6 (270)	12.3 (312)	9.1 (240)	175 (445)	6.6 (167)	12.3 (313)	6.4 (162)	28.3 (718)	26.9 (682)	
<b>WM-G10/1 ZM-LN</b>	32.0 (813)	8.1 (205)	5.1 – 5.7 (129 – 144)	3.5 (88)	11.0 (279)	12.1 (307)	10.6 (270)	12.3 (312)	8.4 (214)	175 (445)	6.6 (167)	12.3 (313)	5.1 (130)	28.3 (718)	26.9 (682)	
<b>WM-G10/2 ZM-LN</b>	32.0 (813)	8.1 (205)	5.2 – 5.6 (132 – 143)	3.9 (98)	11.0 (279)	12.1 (307)	10.6 (270)	12.3 (312)	9.1 (232)	175 (445)	6.6 (167)	12.3 (313)	5.5 (140)	28.3 (718)	26.9 (682)	
<b>WM-G10/3 ZM-LN</b>	32.8 (833)	8.1 (205)	7.0 – 7.8 (177 – 197)	4.3 (108)	11.0 (279)	12.1 (307)	10.6 (270)	12.3 (312)	9.1 (240)	175 (445)	6.6 (167)	12.3 (313)	6.4 (162)	28.3 (718)	26.9 (682)	

Burner Model	Dimension in Inches (mm)					
	d <sub>1</sub>	d <sub>2</sub>	d <sub>3</sub>	d <sub>4</sub>	d <sub>5</sub>	d <sub>6</sub>
<b>WM-G10/1 ZM</b>	6.3" (160)	8.3" (212)	M10	6.5" (165)	7.3" (186)	DN25
<b>WM-G10/2 ZM</b>	6.3" (160)	8.3" (212)	M10	6.5" (165)	7.3" (186)	DN40
<b>WM-G10/3 ZM</b>	7.9" (200)	10.2" (260)	M10	8.3" (210)	9.3" (235)	DN50
<b>WM-G10/4 ZM</b>	8.5" (217)	10.2" (260)	M10	8.7" (220)	9.3" (235)	DN50
<b>WM-G10/1 ZM-LN</b>	5.0" (127)	7.7" (195)	M10	5.3" (135)	6.3-6.7" (160-170)	DN50
<b>WM-G10/2 ZM-LN</b>	6.3" (160)	8.3" (212)	M10	6.5" (165)	7.3" (186)	DN50
<b>WM-G10/3 ZM-LN</b>	7.9" (200)	10.2" (260)	M10	8.3" (210)	9.3" (235)	DN50

### Boiler plate mounting dimensions

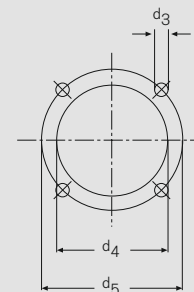

Dimensions given are approximate values. We reserve the right to make changes in line with future developments.

# Dimensions

## Dual fuel burners

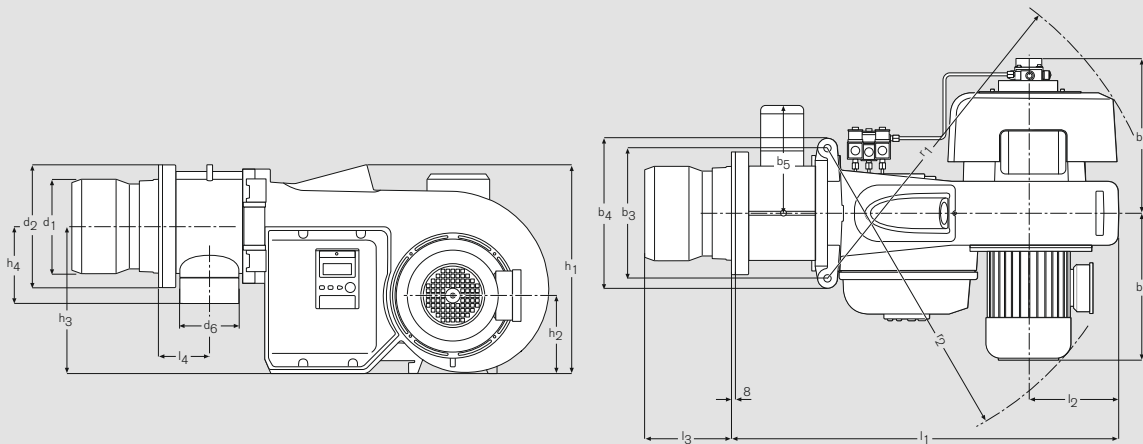

Burner Model	Dimensions in Inches and (mm)															
	l <sub>1</sub>	l <sub>2</sub>	l <sub>3</sub>	l <sub>4</sub>	b <sub>1</sub> <sup>1</sup>	b <sub>2</sub>	b <sub>3</sub>	b <sub>4</sub>	b <sub>5</sub>	h <sub>1</sub>	h <sub>2</sub>	h <sub>3</sub>	h <sub>4</sub>	r <sub>1</sub>	r <sub>2</sub>	
WM-GL10/1 ZM-T	32.0 (813)	8.1 (205)	6.7 – 7.0 (171 – 178)	3.9 (98)	12.7 (323)	12.1 (307)	10.6 (270)	12.3 (312)	9.1 (232)	17.5 (445)	6.6 (167)	12.3 (313)	5.5 (140)	28.3 (718)	26.9 (682)	
WM-GL10/2 ZM-T	32.0 (813)	8.1 (205)	6.2 – 7.0 (158 – 178)	3.9 (98)	12.7 (323)	12.1 (307)	10.6 (270)	12.3 (312)	9.1 (232)	17.5 (445)	6.6 (167)	12.3 (313)	5.5 (140)	28.3 (718)	26.9 (682)	
WM-GL10/3 ZM-T	32.8 (833)	8.1 (205)	7.8 – 8.8 (199 – 224)	4.3 (108)	12.7 (323)	12.1 (307)	10.6 (270)	12.3 (312)	9.4 (240)	17.5 (445)	6.6 (167)	12.3 (313)	6.4 (162)	28.3 (718)	26.9 (682)	
WM-GL10/4 ZM-T	32.8 (833)	8.1 (205)	7.8 – 8.8 (199 – 224)	4.3 (108)	12.7 (323)	12.1 (307)	10.6 (270)	12.3 (312)	9.4 (240)	17.5 (445)	6.6 (167)	12.3 (313)	6.4 (162)	28.3 (718)	26.9 (682)	
WM-GL10/2 ZM-R	32.0 (813)	8.1 (205)	6.2 – 7.0 (158 – 178)	3.9 (98)	13.9 (352)	12.1 (307)	10.6 (270)	12.3 (312)	9.1 (232)	17.5 (445)	6.6 (167)	12.3 (313)	5.5 (140)	28.3 (718)	26.9 (682)	
WM-GL10/3 ZM-R	32.8 (833)	8.1 (205)	7.8 – 8.8 (199 – 224)	4.3 (108)	13.9 (352)	12.1 (307)	10.6 (270)	12.3 (312)	9.4 (240)	17.5 (445)	6.6 (167)	12.3 (313)	6.4 (162)	28.3 (718)	26.9 (682)	
WM-GL10/4 ZM-R	32.8 (833)	8.1 (205)	7.8 – 8.8 (199 – 224)	4.3 (108)	13.9 (352)	12.1 (307)	10.6 (270)	12.3 (312)	9.4 (240)	17.5 (445)	6.6 (167)	12.3 (313)	6.4 (162)	28.3 (718)	26.9 (682)	

① without electromagnetic coupling (with magnetic coupling add 5.1" / 130 mm)

Burner Model	Dimension in Inches (mm)					
	d <sub>1</sub>	d <sub>2</sub>	d <sub>3</sub>	d <sub>4</sub>	d <sub>5</sub>	d <sub>6</sub>
WM-GL10/1 ZM-T	6.3" (160)	8.3" (212)	M10	6.5" (165)	7.3" (186)	DN40
WM-GL10/2 ZM-T	6.3" (160)	8.3" (212)	M10	6.5" (165)	7.3" (186)	DN40
WM-GL10/3 ZM-T	7.9" (200)	10.2" (260)	M10	8.3" (210)	9.3" (235)	DN50
WM-GL10/4 ZM-T	8.6" (218)	10.2" (260)	M10	8.7" (220)	9.3" (235)	DN50
WM-GL10/2 ZM-R	6.3" (160)	8.3" (212)	M10	6.5" (165)	7.3" (186)	DN50
WM-GL10/3 ZM-R	7.9" (200)	10.2" (260)	M10	8.3" (210)	9.3" (235)	DN50
WM-GL10/4 ZM-R	8.6" (218)	10.2" (260)	M10	8.7" (220)	9.3" (235)	DN50

### Boiler plate mounting dimensions

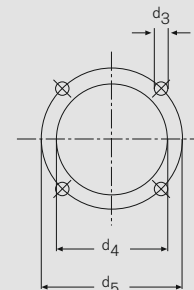

Dimensions given are approximate values. We reserve the right to make changes in line with future developments.

# Function schematics

## Gas train schematic\*

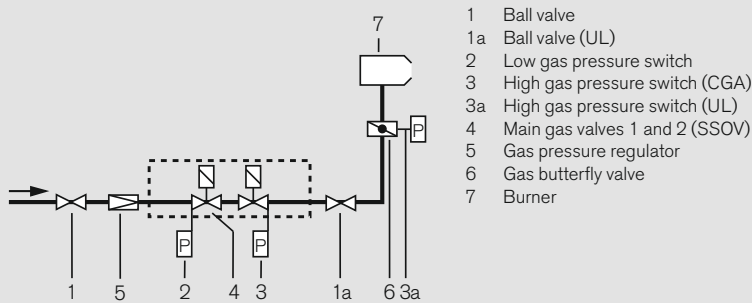

- 1 Ball valve
- 1a Ball valve (UL)
- 2 Low gas pressure switch
- 3 High gas pressure switch (CGA)
- 3a High gas pressure switch (UL)
- 4 Main gas valves 1 and 2 (SSOV)
- 5 Gas pressure regulator
- 6 Gas butterfly valve
- 7 Burner

\* The above schematic shows typical gas train configuration only. The actual gas train configuration shipped with burner might differ depending on applicable codes/ regulation and application.

### Gas train arrangement

For boiler with hinged door the gas train must be installed on the opposite side of the boiler door hinge.

### Gas train installation

Gas train must be mounted tension free. Do not compensate for misalignment by over tightening. Distance between burner and gas valves should be as small as possible. Pay attention to the correct gas flow direction.

### Gas train support

The gas train must be fixed and supported securely. They must not be allowed to vibrate during operation. Support suitable for the site should be fitted during installation.

### Gas meter

For commissioning a gas meter is required to verify exact gas consumption.

## Oil function schematics

### Version ZM-T

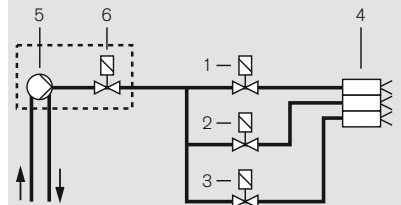

- 1 Solenoid valve stage 1
- 2 Solenoid valve stage 2
- 3 Solenoid valve stage 3
- 4 Nozzle head with 3 oil nozzles
- 5 Burner integrated oil pump
- 6 Safety solenoid valve  
- on burner oil pump (10/1 - 10/3)  
- separate (10/4)

### Version ZM-R

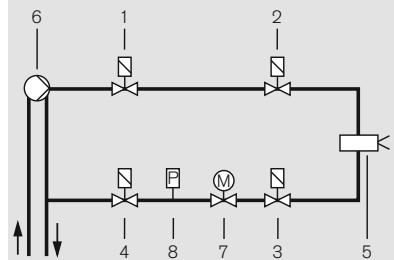

- 1 Normally closed solenoid valve  
1. Shut off device in supply line
- 2 Normally closed solenoid valve  
2. Shut off device in supply line
- 3 Normally closed solenoid valve  
1. Shut off device in return line
- 4 Normally closed solenoid valve  
2. Shut off device in return line
- 5 Nozzle head with regulating oil nozzle
- 6 Burner integrated oil pump
- 7 Oil regulator
- 8 Oil pressure switch in return line



# Saving fuel, reducing emissions: The patented multiflam® technology

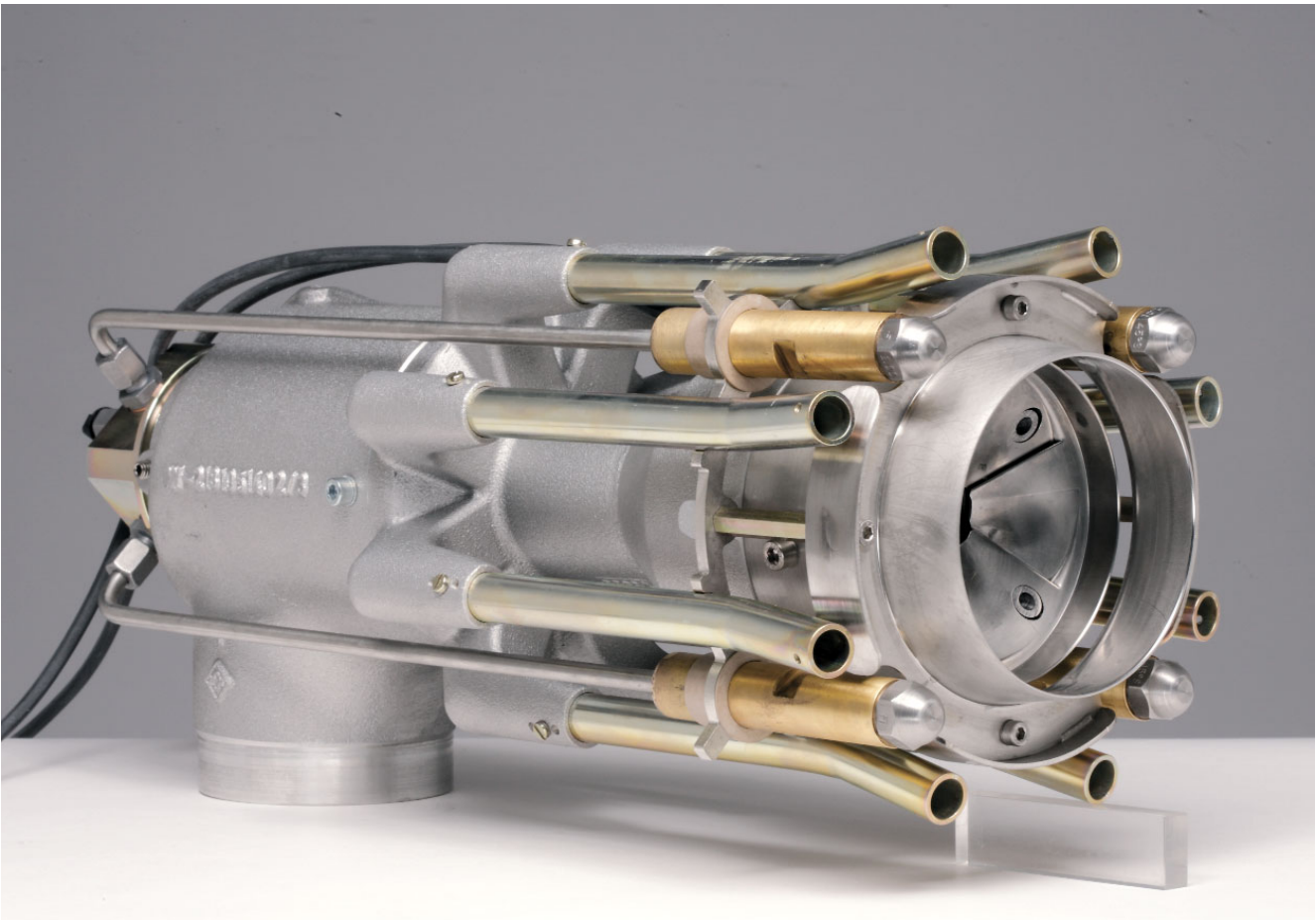

**Patented multiflam® technology allows compliance with the most stringent emission requirements without the need of expensive additional equipment. The emission reduction can be achieved with an innovative mixing head which functions according to fuel distribution principle.**

Weishaupt multiflam® burners have had proven track record for over 10 years. The same excellent technology is now

available for the new monarch burners, which combine medium capacity with low NOx emissions.

#### **Exemplary emission values**

In comparison to standard mixing heads NOx emissions are reduced even further when using 3LN multiflam®. This is achieved by a special mixing head with special fuel distribution principle.

Emission values are also dependent on the combustion chamber geometry, the volume loading and the design of combustion system. Conditions for measurement and assessment, such as combustion chamber loading, measurement tolerances, temperature, pressure, humidity etc. must be observed in order for emission values to be guaranteed.

# Burner selection

## WM 10 multiflam<sup>®</sup> burners version 3LN

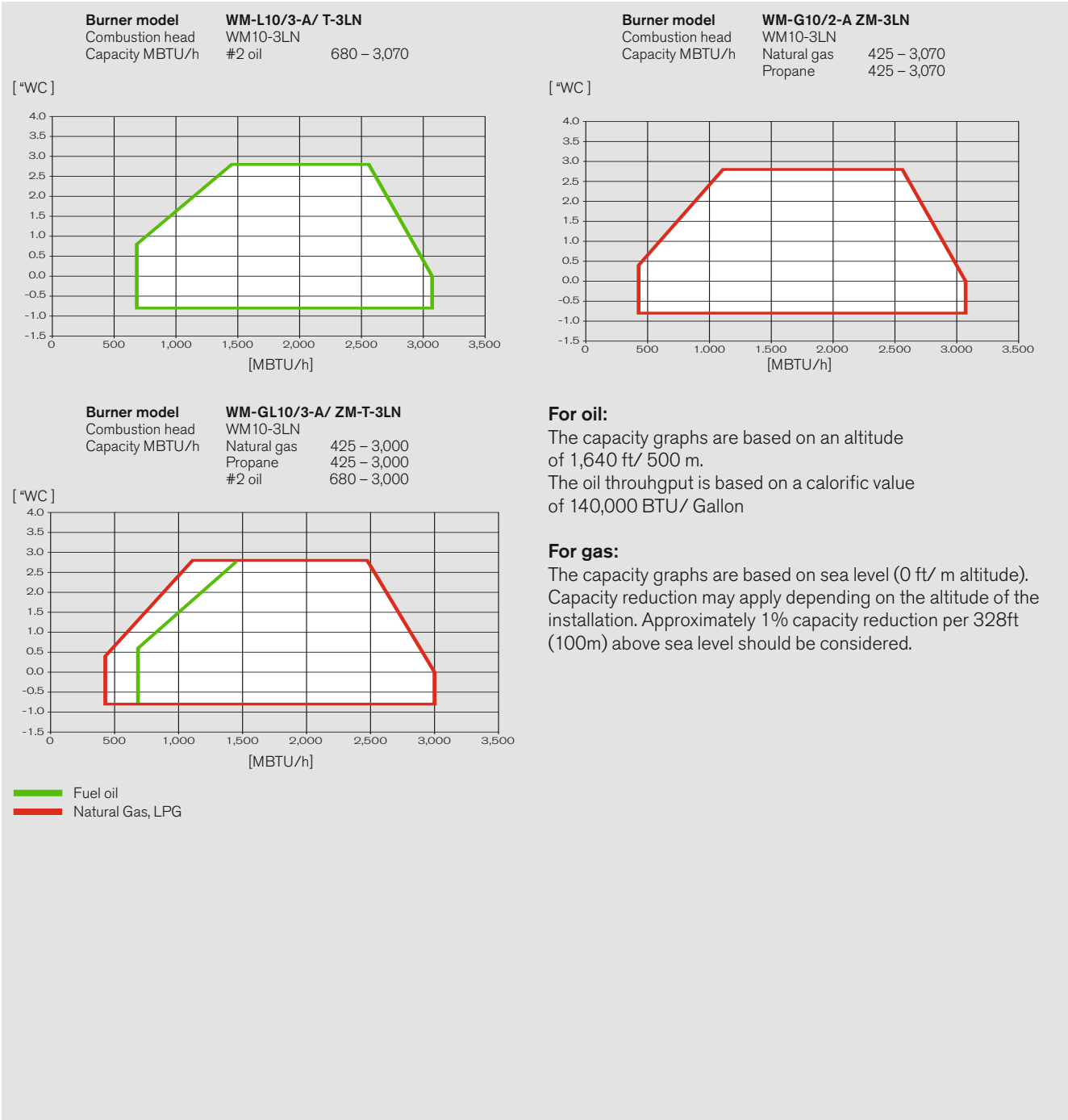

# Standard scope of supply

Description	WM-L10-T-3LN	WM-G10 ZM-3LN	WM-GL10 ZM-T-3LN
Burner housing, hinge flange, housing cover, Weishaupt burner motor, air regulator housing, fan wheel, combustion head, ignition unit, ignition cable, ignition electrodes, combustion manager with operating and display unit, flame sensor, stepping motors, flange gasket, limit switch on hinge flange, fixing screws	●	●	●
Combustion manager W-FM50 W-FM54	● -	● -	- ●
Double safety gas valves	-	●	●
Gas butterfly	-	●	●
Air pressure switch	-	●	●
Adjustable mixing head	●	●	●
Stepping motor for fuel/air compound regulation with W-FM:			
Stepping motor for air regulator	●	●	●
Stepping motor for gas butterfly valve	-	●	●
Burner mounted oil pump	●	-	●
Oil hoses	●	-	●
3 oil solenoid valves, three stage nozzle head with premounted oil nozzle 1 additional oil safety solenoid valve	●	-	●
Type of protection IP 54	●	●	●

● Standard  
○ Optional

# Order numbers Accessories

## Oil burner

Burner model	Version	Order No.
WM-L10/3-A	T-3LN	211 110 34

## Dual fuel burner

Burner model	Version	Order No.
WM-GL10/3-A	ZM-T-3LN	218 122 10

## Gas burner

Burner model	Version	Order No.
WM-G10/3-A	ZM-3LN	217 122 10

## Accessories

Oil burner	WM-L 10/3 T-3LN
Combustion head extension	250 030 59
	by 4" (100 mm)
	by 8" (200 mm)
Solenoid valve for air press. switch test - cont. run fan or post purge	250 030 21
Oil hoses 50" (1300) mm instead of 40" (1000 mm)	210 003 00
Ducted air intake with additional pressure switch	210 030 20
Electromagnetic clutch for oil pump	250 030 44
W-FM 100 in lieu of W-FM 50 (suitable for continuous operation)	250 030 74
W-FM 200 in lieu of W-FM 50 with built in modulating control and speed control module, with optional fuel metering	250 030 75
Oil meter VZ08	250 030 46
Oil meter VZ08 with remote transmitter LF	250 030 47
Special voltage (on request only)	on request

# Accessories

<b>Gas and dual fuel burners</b>		<b>WM-G10/3 ZM-3LN</b>	<b>WM-GL10/3 ZM-T-3LN</b>
Combustion head extension	by 4" (100 mm)	250 031 57	250 031 59
	by 8" (200 mm)	250 031 58	250 031 60
Oil hoses 50" (1300) mm instead of 40" (1000 mm)		–	210 003 00
Electromagnetic coupling		–	250 030 44
Ducted air intake with additional pressure switch		250 030 24	210 030 20
Oil meter VZ08 fitted		–	250 030 46
Oil meter VZ08 with remote transmitter NF, fitted (external wiring of NF req.)		–	250 030 47
Solenoid valve for air pressure switch test for continuous run fan or post-purge		250 030 21	250 030 21
W-FM 100 in lieu of W-FM 50 (suitable for continuous operation)		250 030 74	–
W-FM 200 in lieu of W-FM 50 with built in modulating controller and speed control module, with optional fuel metering		250 030 75	–
W-FM 100 in lieu of W-FM 54 (suitable for continuous operation) with built in modulating controller	fitted	–	250 031 78
	loose	–	on request
W-FM 200 in lieu of W-FM 54 with built in modulating controller and speed control module, with optional fuel metering	fitted	–	250 031 77
	loose	–	on request
Speed control with burner motor mounted VFD (W-FM 54/200 required)		on request	on request
Speed control with separate VFD (W-FM 54/200 required)		on request	on request
Special voltages (on request only)		on request	on request



## Technical Data

<b>Oil burner</b>		<b>WM-L 10/3-A / T 3LN</b>
Burner motor	Weishaupt model	WM-D90/90-2/1K5
Rated power	HP (kW)	2.14 (1.6)
Current	A	3.1 (@ 460 V)
Motor fusing (direct online)	A minimal	16 A slow (external)
Speed (60 Hz)	rpm	3,480
Combustion manager	Model	W-FM 50
Flame monitoring	Model	QRA2
Stepping motor air/gas	Model	STE 50
Weight	lbs (kg)	approx. 125 (56)

<b>Gas burner</b>		<b>WM-G 10/3-A/ ZM-3LN</b>
Burner motor	Weishaupt model	WM-D90/90-2/1K5
Rated power	HP (kW)	2.14 (1.6)
Current	A	3.1 (@ 460 V)
Motor fusing (direct online)	A minimal	16 A slow (external)
Speed (60 Hz)	rpm	3,480
Combustion manager	Model	W-FM 50
Flame monitoring	Model	ION
Stepping motor air/gas	Model	STE 50
Weight	lbs (kg)	approx. 125 (56)

<b>Dual fuel burner</b>		<b>WM-GL 10/3-A/ ZM-T 3 LN</b>
Burner motor	Weishaupt model	WM-D90/90-2/1K5
Rated power	HP (kW)	2.14 (1.6)
Current	A	3.1 (@ 460 V)
Motor fusing (direct online)	A minimal	16 A slow (external)
Speed (60 Hz)	rpm	3,480
Combustion manager	Model	W-FM 54
Flame monitoring	Model	QRA2
Stepping motor air/gas/ oil	Model	STE 50
Burner mounted oil pump	Model GPH (l/h)	AL95C 40 (150)
Oil hoses	DN/length	5/16" / 40" ( 8/1000)
Weight	lbs (kg)	approx. 128 (58)

# Dimensions

## multiflam® oil burner version 3LN

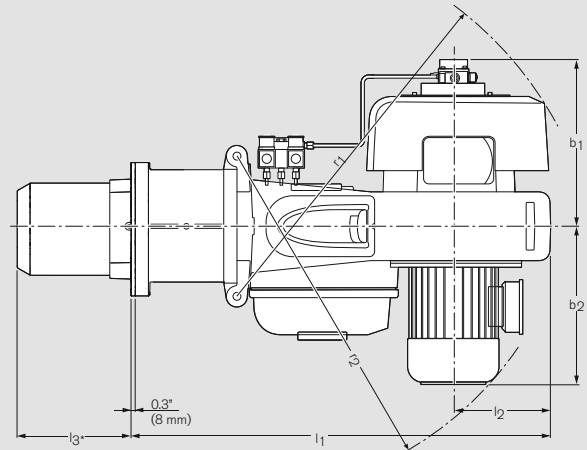
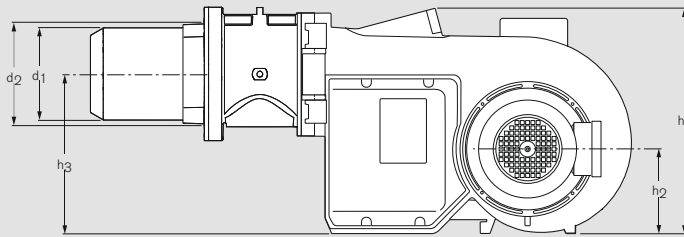

Burner type	Dimensions in inches (mm)			b1	b2	h1	h2	h3	r1	r2	d1	d2
	l1	l2	l3 <sup>1)</sup>									
WM-L10/3 T-3LN	32.8 (833)	8.1 (205)	8.15 – 8.7 (207 – 222)	12.7 (323)	12.1 (307)	17.5 (445)	6.6 (167)	12.3 (313)	28.3 (718)	26.9 (682)	7.1 (180)	7.8 (199)

<sup>1)</sup> 8.15 – 8.7 (207 – 222 mm) without combustion head extension  
 12.15 – 12.7 (307 – 322 mm) with 4" (100 mm) combustion head extension  
 16 – 16.6 (407 – 422 mm) with 8" (200 mm) combustion head extension

## multiflam® gas burner version 3LN

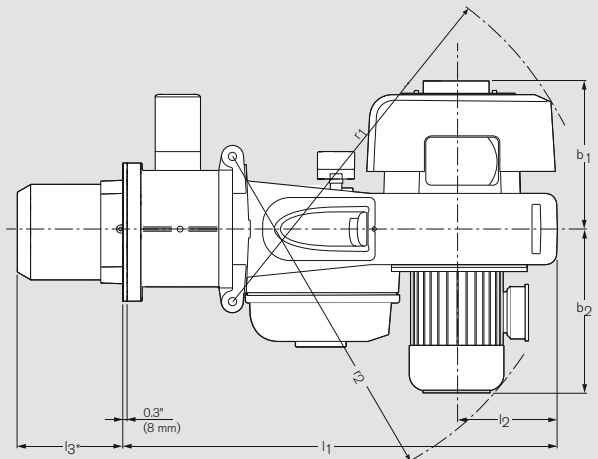
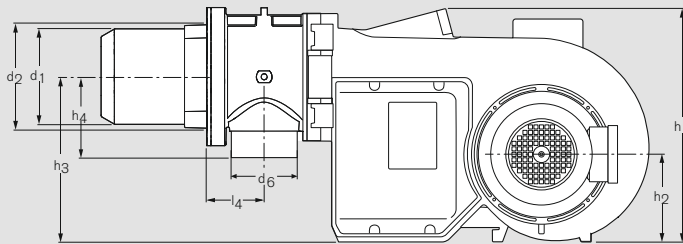

Burner type	Dimensions in inches (mm)			l4	b1	b2	h1	h2	h3	h4	r1	r2	d1	d2	d6
	l1	l2	l3 <sup>2)</sup>												
WM-G10/3 ZM-3LN	32.8 (833)	8.1 (205)	8.3 – 8.7 (212 – 222)	4.3 (108)	11.0 (279)	12.1 (307)	17.5 (445)	6.6 (167)	12.3 (313)	6.3 (161)	28.3 (718)	26.9 (682)	7.1 (180)	7.8 (199)	DN50

<sup>2)</sup> 8.3 – 8.7 (212 – 222 mm) without combustion head extension  
 12.3 – 12.7 (312 – 322 mm) with 4" (100 mm) combustion head extension  
 16.2 – 16.6 (412 – 422 mm) with 8" (200 mm) combustion head extension

All dimensions are approximate. Weishaupt reserve the right to make changes in light of future developments.

# Dimensions

## multiflam® dual fuel burner version 3LN

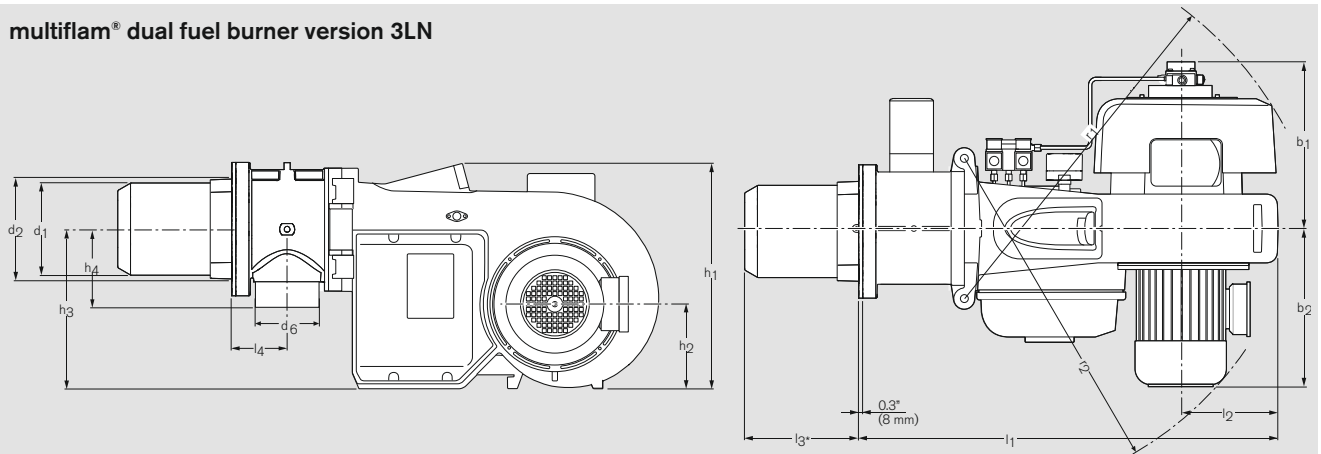

Burner model	Dimensions in inches (mm)														
	l1	l2	l3 <sup>1)</sup>	l4	b1	b2	h1	h2	h3	h4	r1	r2	d1	d2	d6
WM-GL10/3 ZM-T 3LN	32.8 (833)	8.1 (205)	8.3 – 8.7 (212 – 222)	4.3 (108)	12.7 (323)	12.1 (307)	17.5 (445)	6.6 (167)	12.3 (313)	6.3 (161)	28.3 (718)	26.9 (682)	7.1 (180)	7.8 (199)	DN50

<sup>1)</sup> 8.3 – 8.7 (212 – 222 mm) without combustion head extension  
 12.3 – 12.7 (312 – 322 mm) with 4" (100 mm) combustion head extension  
 16.2 – 16.6 (412 – 422 mm) with 8" (200 mm) combustion head extension

All dimensions are approximate. Weishaupt reserve the right to make changes in light of future developments.

### Burner plate mounting dimensions

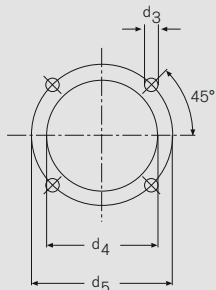

d<sub>3</sub> = M10  
 d<sub>4</sub> = 8.3 (210 mm)  
 d<sub>5</sub> = 9.3 (235 mm)

### Preparing the heat exchanger

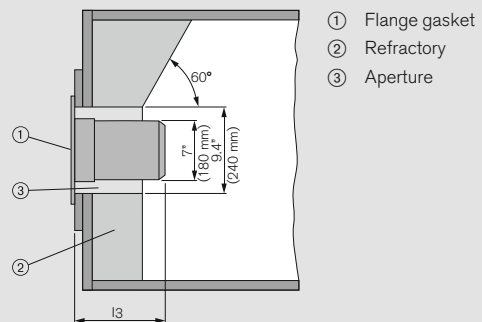

The refractory ② must not protrude beyond the front edge of the combustion head, it can however, take a conical shape (min 60°).

# Fuel systems

## Gas train schematic\*

W-FM 50/100/200

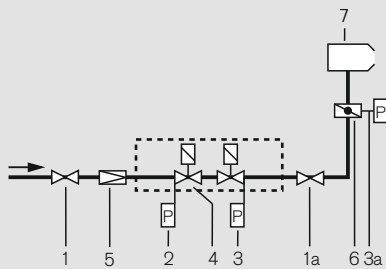

- 1 Ball valve
- 1a Ball valve (UL)
- 2 Low gas pressure switch
- 3 High gas pressure switch (CGA)
- 3a High gas pressure switch (UL)
- 4 Main gas valves 1 and 2 (SSOV)
- 5 Gas pressure regulator
- 6 Gas butterfly valve
- 7 Burner

\* The above schematic shows typical gas train configuration only. The actual gas train configuration shipped with burner might differ depending on applicable codes/ regulation and application.

### Gas train arrangement

For boiler with hinged door the gas train must be installed on the opposite side of the boiler door hinge.

### Gas train installation

Gas train must be mounted tension free. Do not compensate for misalignment by over tightening. Distance between burner and gas valves should be as small as possible. Pay attention to the correct gas flow direction.

### Gas train support

The gas train must be fixed and supported securely. They must not be allowed to vibrate during operation. Support suitable for the site should be fitted during installation.

### Gas meter

For commissioning a gas meter is required to verify exact gas consumption.

## Oil function schematics

Version ZM-T

(two stage with ignition stage)

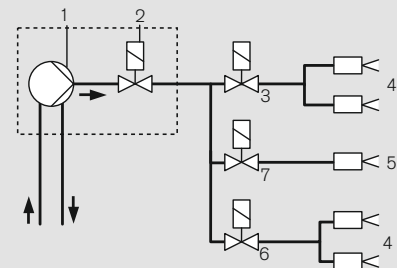

- 1 Oil pump on burner
- 2 Solenoid valve on oil pump
- 3 Solenoid valve operating stage 1
- 4 Secondary nozzles
- 5 Primary nozzles
- 6 Solenoid valve operating stage 2
- 7 Solenoid valve ignition stage

That is not a Facade. Weishaupt has been one of the leading company in heating and combustion industry since years with headquarter in Schwendi and branches all over the world. That is Reliability.



**Weishaupt is Reliability.**

*The family business in Schwendi was established by Max Weishaupt in 1932. Represented in 55 countries by branch offices and subsidiaries Weishaupt is international leader in the areas of combustion technology and heating applications.*

*Trustworthy, quality, good customer service, innovation and experience are values on which the Pioneer Max Weishaupt established his company. All this combined in a word is reliability.*

*Therefore stands Weishaupt today.*





That is not an Imagination. Continuous research and development at Weishaupt ensure environmental friendly and efficient burners. That is Reliability.



*Test facility at Weishaupt R&D centre*





**Developing improvement.**

Weishaupt recognizes the signs of time and researches perpetually to get more efficient and environmental friendly burner systems.

This way not only Weishaupt prevents largely unnecessary energy cost but also actively contributes in conserving the environment.

# – weishaupt –

Weishaupt Corporation  
6280 Danville Road  
Mississauga, ON L5T 2H7  
Ph: (905) 564 0946  
Fax: (905) 564 0949  
[www.weishaupt-corp.com](http://www.weishaupt-corp.com)

Weishaupt America Inc.  
2587 Millennium Drive, Unit A  
Elgin, IL, 60124  
Ph: (847) 531 5800  
Fax: (847) 531 5855  
[www.weishaupt-america.com](http://www.weishaupt-america.com)

Print No. 83211416, December 2011  
Printed in Germany. All rights reserved.



Regular maintenance reduces heating costs and environmental pollution. Only a properly adjusted burner can save energy and be environmentally friendly. Behind each Weishaupt burner stands the whole Weishaupt customer service organization. The outstanding efforts made in maintenance and service justify the enormous trust placed in Weishaupt's burners, for at Weishaupt, product and customer service belong together.

Weishaupt customer service is there for you all year round. Whenever you need help, be it the supply of spare parts, technical advice or a site visit. We are there when you need us.